



High-Bright Color

## Advantages of High-Bright Color LCDs for PACS

TOTOKU

White Paper



## ADVANTAGES OF HIGH-BRIGHT COLOR LCDs FOR PACS

### Table of Contents

1. PREFACE -----	2
2. THE TREND OF COLOR IMAGING AND ADVANTAGES OF HIGH-BRIGHT COLOR LCD -----	2
2-1 Overview of LCD's used with Today's PACS -----	2
2-2 Demands and Advantages of Color LCDs-----	2
3. TECHNOLOGY BEHIND THE HIGH-BRIGHT COLOR LCD -----	4
3-1 Mechanism of Color LCDs -----	4
3-2 Challenges and Solutions of Delivering High-bright Color -----	4
4. SUMMARY -----	6

11/25/2005 Ver. 5.8  
M.H.

## 1. PREFACE

The Picture Archive and Communication System (PACS) introduced in the early 1990's, was a computer system designed to provide aid in diagnostic image reading and data management, in the world of conventional X-ray films. Initially, these systems were handling monochrome images generated from Ultrasound, CT and MRI. As the technology of diagnostic devices and IT advanced, the use of color images has become more prominent.

This advance in technology is driving increased demand for PACS monitors capable of diagnostic color image reading. Commercially available color LCDs are not adequate for diagnostic reading of grayscale images because both the brightness and the contrast levels are too low compared to monochrome displays. Therefore, a mix of color and monochrome LCDs is a common configuration for today's PACS to support reading different applications.

It is evident that there is strong demand from the medical facilities for a single monitor that is capable of reading both greyscale and Color applications. To meet such a demand, TOTOKU has developed the high-bright, high-resolution color "CCL250i" and "CCL350i" LCD solutions.

This white paper describes the trend of color imaging in the medical field, the advantages of the high-bright color LCD, and technologies supporting our high-bright color LCD.

## 2. THE TREND OF COLOR IMAGING AND ADVANTAGES OF HIGH-BRIGHT COLOR LCD

### 2.1 Overview of LCD's used with today's PACS

A typical configuration in today's PACS workstation consists of a mix of displays; some monochrome LCD's for medical image displays and some color LCD's for 3D or menu list. There are two types of color LCD's available: the general purpose commercial color LCD that are usually used with PCs, and the medical LCD used for medical image display that support DICOM calibration capabilities. Commercial color LCD's are not considered adequate for diagnostic reading because these types of displays do not feature brightness stabilization systems and are difficult to maintain the display quality. Display quality is required by the DICOM Grayscale Standard Display Function (GSDF), so commercial units are mainly used in PACS/RIS operations. The color LCD's used for medical image displays are generally equipped with both a brightness stabilization system and calibration capability, and also comply with the DICOM GSDF. However, most are still inadequate for diagnostic image reading due to a low brightness setting in the 100-150cd/m<sup>2</sup> range and the inability to maintain brightness stability for a long period of time. A guideline concerning medical display devices, AAPM-TG18 (American Association of Physicists in Medicine Task Group 18) recommends a minimum brightness of 170cd/m<sup>2</sup> for medical image diagnostic reading. Brightness less than the minimum recommended level is too low to obtain JNDs (Just Noticeable Differences) necessary for diagnostic reading.

Thus, today's typical PACS workstations are configured with a mix of displays, some monochrome monitors for medical image displays and some color displays in order to support different applications.

### 2.2 Demands and Advantages of Color LCDs

This section describes why TOTOKU has developed the high-bright color displays for today's PACS environment.

First, the use of color data in the medical field has become prominent over the past 10 years. Two different types of color images displayed on a PACS system are as follows:

One type of image starts as a monochrome image when captured and is colorized during subsequent processes by the diagnostic equipment. Examples are 3D rendering of CT, MRI, Doppler ultrasound, and Computer Aided Diagnosis (CAD). The other type is where the color image is natively generated by the diagnostic devices, resulting in color from the start. Some examples are the Single Photon Emission Computed Tomography (SPECT) images and the Positron Emission Tomography (PET) images used in the

areas of nuclear medicine, ultrasound, and endoscopic images. At large hospitals, implementation of PACS is growing beyond the radiology departments and expanding to internal medicine, orthopedics, ophthalmology, and the dermatology departments. These new applications create more diversity and frequency of color images.

In summary, this trend in medical color imaging is driving an increasing demand for color displays that are suitable for diagnostic reading and use as the primary monitor with workstations. To date, color displays have been mainly used as secondly monitors.

Additionally, there is a move to view monochrome images with a high-bright color monitor. Let's look at how users would benefit from the high-bright color monitors:

With the availability of high-bright color displays capable of use with all applications, the PACS workstation can be simpler to configure or configured with more flexibility according to the applications. As long as monochrome displays are still superior providing higher brightness and contrast, not all displays can be replaced with high-bright color monitors (CT and Mammography as an example). However, making the color displays available for diagnostic reading is a significant step forward.

A high bright color display offering allows the end user the option of deploying a true 'multi-use' workstation within their facility. This workstation may view both color and grayscale images from a variety of modalities, without the need for multiple displays. The use of a high bright color LCD display helps contribute to PACS cost reduction, wherever a color and grayscale Workstation can be combined. This solution not only reduces cost, but also reduces the physical footprint of the workstation.

When you consider the impact of possible implementation of acceptance and constancy test for all medical monitors, a reduction in the total number of monitors makes QA control easier. In summary, the users will benefit with the reduction of Total Cost of Ownership (TCO).

As imaging technology advances, we expect to see color integrated into predominantly grayscale environments, similar to what happened with ultrasound in the past decade. Facilities who own high resolution color display systems, will be compatible with future diagnostic equipment improvements.

PACS graphical user interfaces designed and displayed in color are more intuitive and easier to use. The color diagnostic display takes advantage of this fact, making the user interface easier to use. Colors may be used to group icons depending on function, or icons may be made to change colors registering state. PACS workstation users also often run Radiology Information System (RIS) applications and web browsers, and it is obvious that the color displays deliver better performance than monochrome for such applications.

To benefit from the advantages mentioned above, the high-bright color monitors have to be able to offer grayscale display capabilities comparable to conventional monochrome displays, meeting the DICOM and exceeding the ACR standards. The high-bright color monitors developed by TOTOKU feature a maximum brightness of 400cd/m<sup>2</sup> or more, and are able to set the brightness to 200-250cd/m<sup>2</sup> when users require brightness stability for a long period of time. With advancing technologies offering such high brightness as well as the grayscale display capabilities comparable to the medical monochrome displays, we are bringing a new future for the color LCD.

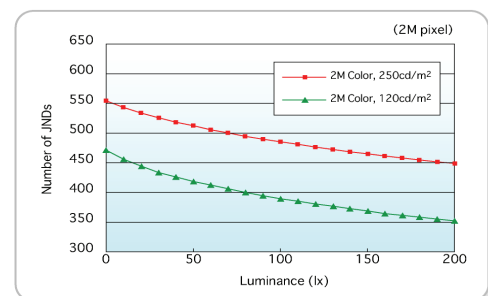

Figure 1. Relationship between JNDs and luminance

Our high-bright color LCDs offer a significant increase in perceivable shades compared to commercially

available LCDs; the number of JNDs is 20% higher in the entire 0-200 lux luminous range (See Figure 1).

As mentioned above, the most important challenge in developing color monitors adequate for medical systems including PACS is achieving higher brightness. The next section describes the technical aspects of our high-bright color technology.

### 3. TECHNOLOGY BEHIND THE HIGH-BRIGHT COLOR LCD

This chapter describes the technical background; how color LCDs work and why color LCD's brightness is generally lower than the monochrome LCD, and tells how we overcame the challenge to develop our high-bright color monitors.

#### 3.1 Mechanism of Color LCDs

Unlike CRTs and plasma displays that produce self-emitted light, the LCD panel displays images by passing light through from a light source (backlight), placed in the rear of the panel. As the light transmits through the liquid crystal cells (pixels), the amount of light penetration is controlled. Each pixel of the color LCD panel is made up of three sub-pixels, red, green and blue, with polarizing filters (Figure 2), and as the light penetrates through these three sub-pixels and reaches the human eyes, additive colors form images.

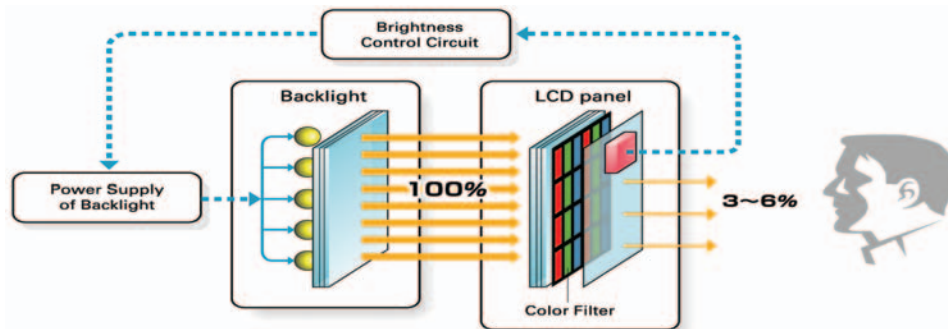

Figure 2. LCD Panel Construction Details

As shown in Figure 2, because the color LCD panels select colors using the white backlight which penetrates through three color filters, the transmission factor of light is lower than that of the monochrome LCD panels. The transmission factor of color LCD glass is about one-fifth of monochrome LCD glass; color LCD is 3-6% and monochrome LCD is 15-30%. This means that the color LCD panels have to be five times brighter to achieve the same brightness as monochrome LCD panels. However, simply increasing brightness alone will cause other problems such as a shorter life of the backlight and an increase in temperature causing unstable brightness.

The higher the resolution, the more difficult it is to achieve higher brightness. This is because the apertures of the cells (pixel fill factor) get smaller as the resolution gets higher; assuming the panel size is constant.

#### 3.2 Challenges and Solutions of Delivering High-bright Color

How did we overcome the challenges mentioned above? The TOTOKU high-bright color LCDs were made possible with our advanced design technology and implementation of the most effective materials. Specifically, we have optimized the backlight and the circuits, improved the heat dissipation design accordingly, and integrated a highly accurate brightness stabilizing circuit and light condensing lenses. The details of each item are described below:

### 3.2.1 Optimizing the backlight and the circuit

There are two types of LCD backlights. One is called an edge type that mounts the CCFL lamps both at the top and bottom of the panel edges. This type is effective in keeping the panels thinner, but is not able to accomplish higher brightness. The other is called the direct type, which has the CCFL lamps located directly behind the liquid crystal cells. This method is more effective in achieving higher brightness compared to the edge type. Using the direct type and increasing the output of individual CCFL lamps, we have achieved higher brightness. Consequently, we have also optimized the inverter circuit for the backlight to support higher loads.

### 3.2.2 Heat dissipation design

Making the backlight brighter raises the internal temperature of the display. This causes heat stress to individual parts in the display, preventing the secure stability of internal circuits of the monitor which are crucial for display stability. Overheating could also contribute to shortening of the product life. While cooling fans are effective in lowering the internal temperature, the noise generated by the fans are undesirable for image reading.

We have achieved a precise heat dissipation design by utilizing our unique simulation technique which has been developed over many years. With this design, natural heat dissipation is sufficient and there is no need to run cooling fans under normal temperature; only when the room temperature is 30 degrees C or higher, will the fans be activated to force cooling. We have achieved the initial design goal of a stabilized display by managing heat with minimum fan cooling (with brightness setting of 200cd/m<sup>2</sup>).

Simulations were performed analyzing the mechanisms of the monitor's interior and its heat source parts. As a result, we were able to optimize locations of the heat source parts, the ventilation opening space, and location for heat exhaust slit, as well as the position of the cooling fan and its capacity. Additionally, the medical displays may be used in both landscape and portrait orientations. Recognizing that changing LCD orientation affects the internal temperature status, the simulations were performed in both orientations.

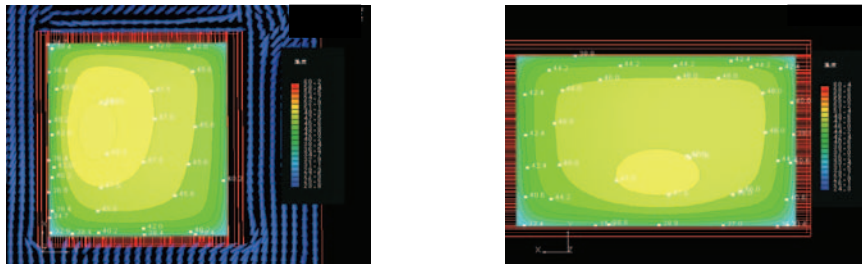

Figure 3. Heat dissipation simulation test results

### 3.2.3 Highly accurate brightness stabilizing circuit

The characteristic of the panel's brightness changes remarkably when the internal temperature changes, as shown in Figure 4. Thermal stability is required for diagnostic image review.

Our high-bright color LCDs are equipped with a sensor in front of the panel connected to a brightness stability feedback loop to control not only the backlight but also the entire LCD panel and its driver circuit based on the measured brightness values by the sensor.

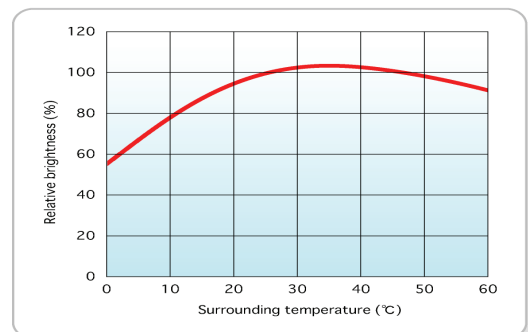

Figure 4. Relationship between relative brightness and ambient temperature

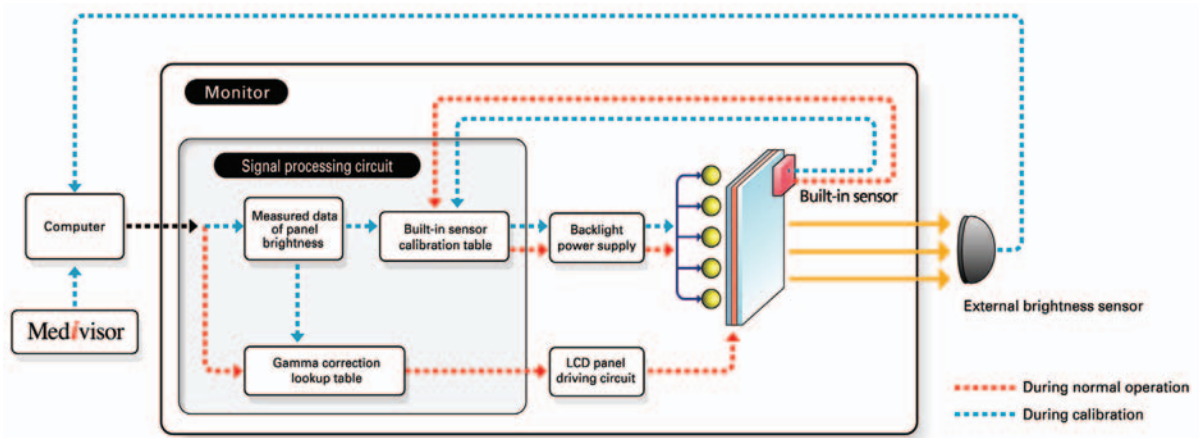

Figure 5. Brightness detection feedback loop

The brightness feedback system is optimized to measure the light transmitted through the liquid crystal cells by using the “sensor elements,” the “micro current amplification circuit,” and its “firmware,” then realizes the high accurate brightness stability for the entire grayscale range from minimum to maximum luminance based on measured data by the sensor.

### 3.2.4 Light condensing lenses

As mentioned in the previous section, the higher the resolution, the more difficult it is to increase brightness. We overcame this challenge by using light condensing lenses for our 3Mega high-bright color LCDs. As shown in Figure 6, the light condensing lenses work as micro-convex-lens films which are placed at each of the RGB cells behind a liquid crystal cell layer. This diffracts the backlight towards the opening of the cells to transmit the light otherwise absorbed in the black strips. This effective use of the backlight achieves higher brightness.

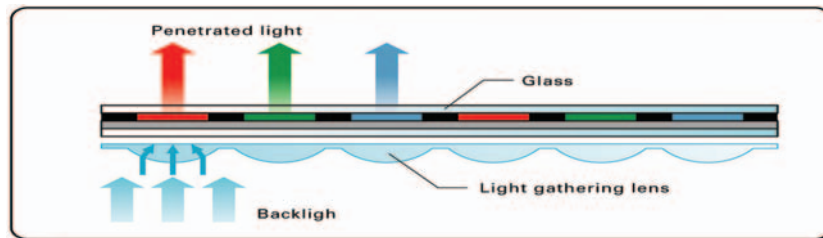

Figure 6. Diagram of light condensing lenses

As mentioned above, the simple solution of stronger output of backlight to achieve higher brightness would cause the instability of operation. The use of light condensing lenses resulting in higher display brightness without changing the backlight output itself was an ingenious achievement.

## 4. SUMMARY

This document described the trend in color imaging and the advantages of the high-bright color LCDs and the supporting technologies. TOTOKU high-bright color LCD monitor is a breakthrough in the industry and its impact in the medical information systems including PACS is expected to offer many advantages to the users.

TOTOKU ELECTRIC CO., LTD.  
Engineering Group  
Intelligent Devices & Solutions Company